

STAMPED MUFFLER GUARD

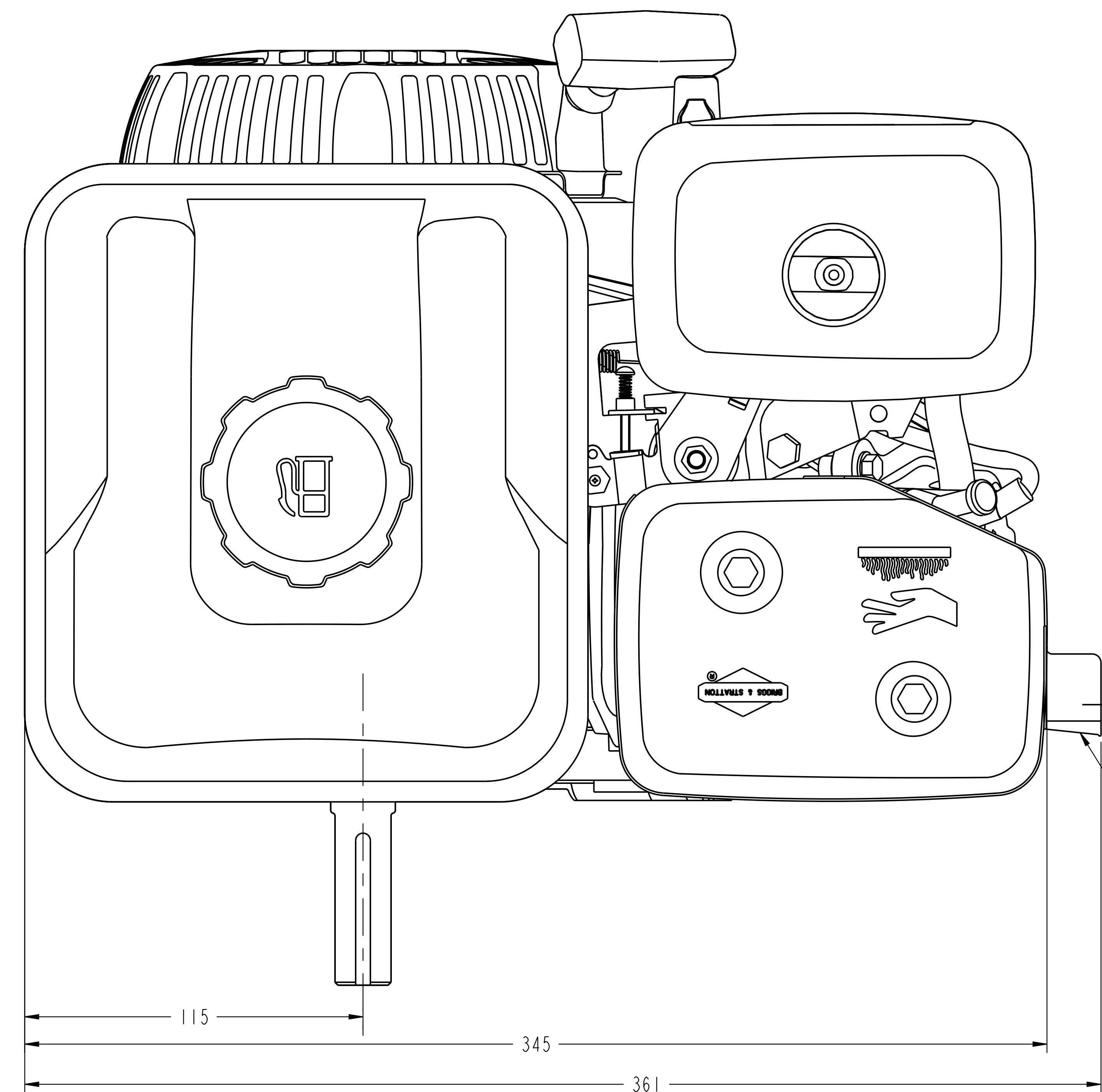

"OVAL-STYLE" AIR CLEANER
WITH STAMPED MUFFLER GUARD

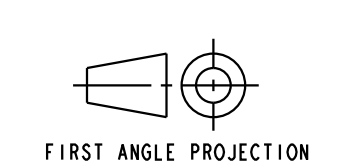

REFER TO 3-D DATA FOR ADDITIONAL INFORMATION		PROPERTY OF BRIGGS & STRATTON CORPORATION. THIS DRAWING IS PROPRIETARY AND NOT TO BE REPRODUCED OR TRANSMITTED IN ANY FORM OR BY ANY MEANS, ELECTRONIC OR MECHANICAL, INCLUDING PHOTOCOPYING, RECORDING, OR BY ANY INFORMATION STORAGE AND RETRIEVAL SYSTEM. RETURN PROMPTLY AFTER USE.		DIMENSIONS IN MILLIMETERS TOLERANCING PER ASME Y14.5M-1994		SCALE: 1:1		UNCONTROLLED DOCUMENT WHEN PRINTED	
THIS DRAWING IS PROPRIETARY PROPERTY OF BRIGGS & STRATTON CORPORATION. IT IS NOT TO BE REPRODUCED OR TRANSMITTED IN ANY FORM OR BY ANY MEANS, ELECTRONIC OR MECHANICAL, INCLUDING PHOTOCOPYING, RECORDING, OR BY ANY INFORMATION STORAGE AND RETRIEVAL SYSTEM. RETURN PROMPTLY AFTER USE.		DIMENSIONS IN MILLIMETERS TOLERANCING PER ASME Y14.5M-1994		CLASSIFICATION OF CHARACTERISTICS		DRAWN: DTS 02/10/09 APPR: JHW 02/11/09		TITLE: MODEL 831 ENGINE APPLICATION DRAWING	
DOUBLE MAJOR(MM_00) CRITICAL(C_00) MAJOR(M_00)		MATERIAL:		DO NOT SCALE DRAWING		83100-0000-16		REV SHEET 1 OF 8	

REV	CHANGES	BY	DOC. NO.	DATE
-	RELEASED FOR PRODUCTION	DTS	ERN10385	02/11/09
A	REDRAWN: ADDED SHEETS SHOWING ENGINE OPTIONS	DTS	ECO17477	06/22/09

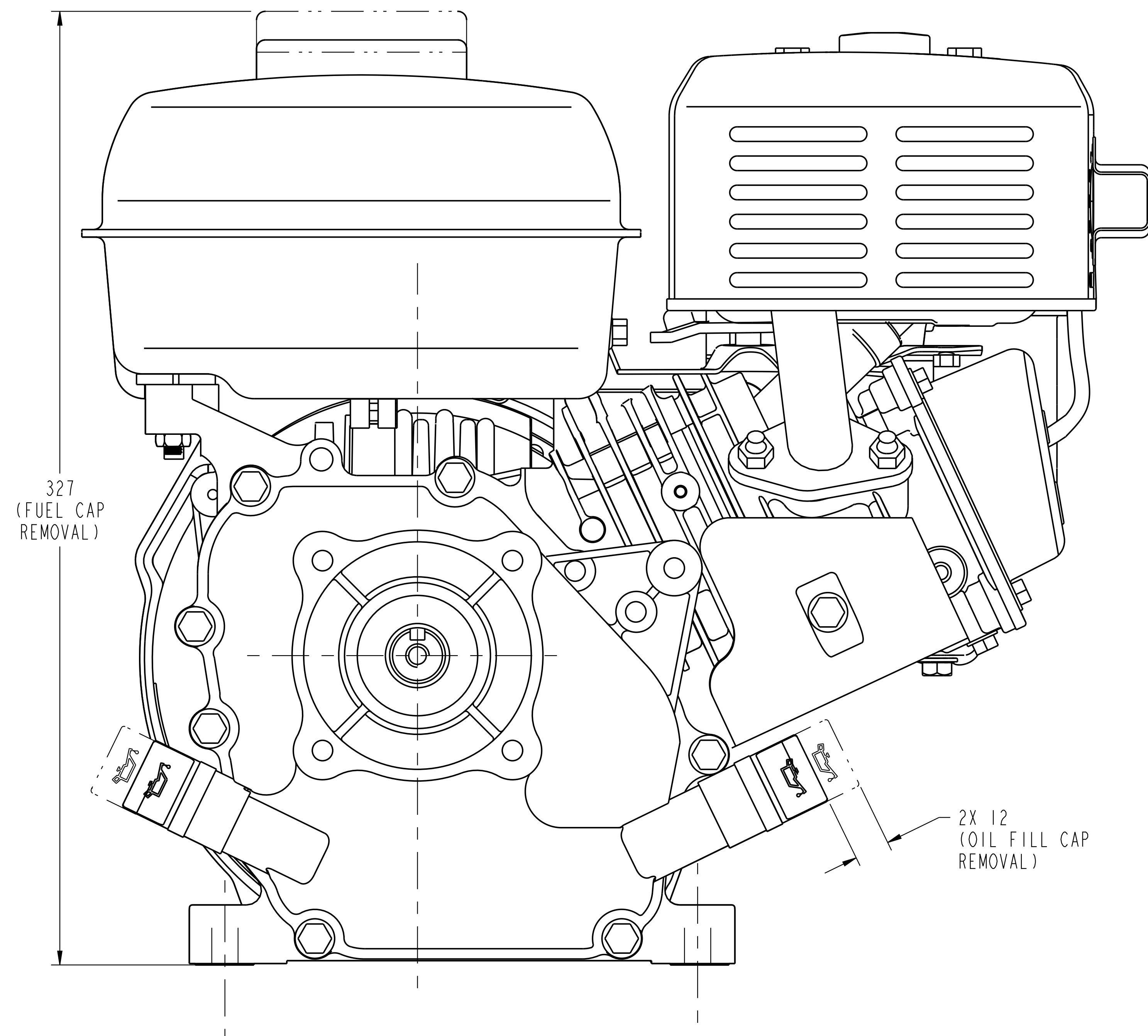
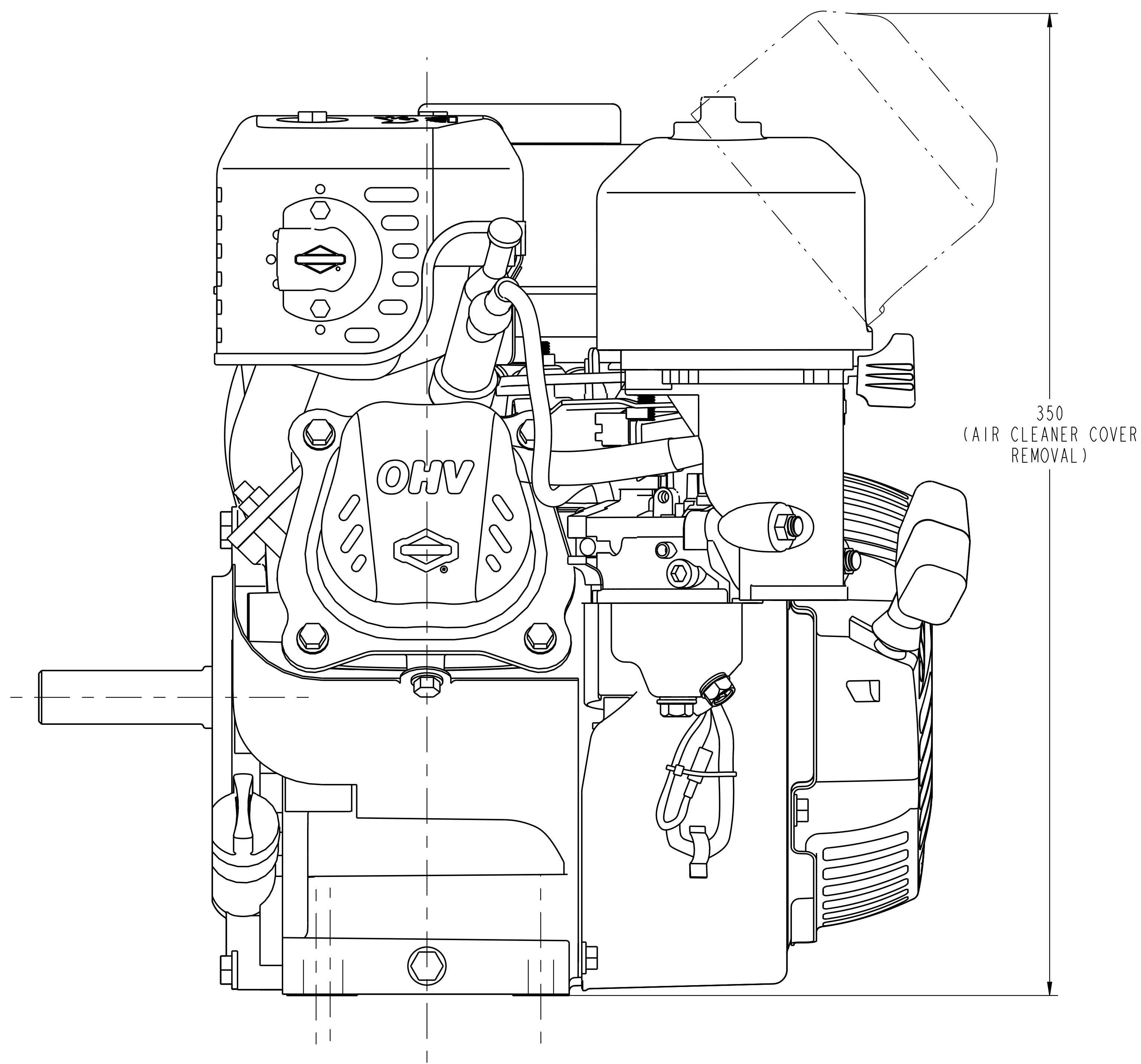

**"OVAL-STYLE" AIR CLEANER
WITH STAMPED MUFFLER GUARD**

REV	CHANGES	BY	DOC. NO.	DATE
-	RELEASED FOR PRODUCTION	DTS	ERN10385	02/11/09
A	REDRAWN: ADDED SHEETS SHOWING ENGINE OPTIONS	DTS	ECO17477	06/22/09

REFER TO 3-D DATA FOR ADDITIONAL INFORMATION

THIS DRAWING IS PROPRIETARY PROPERTY OF BRIGGS & STRATTON CORPORATION. IT IS TO BE USED ONLY FOR THE PURPOSES SPECIFIED HEREIN. RETURN PROMPTLY AFTER USE.

DIMENSIONS IN MILLIMETERS

CLASSIFICATION OF CHARACTERISTICS

DOUBLE MAJOR(MM-.00) CRITICAL(C-.00) MAJOR(M-.00)

FIRST ANGLE PROJECTION

SCALE: 1:1

UNCONTROLLED DOCUMENT WHEN PRINTED

TITLE: MODEL 831 ENGINE APPLICATION DRAWING

MATERIAL:

DRAWN: DTS 02/10/09
APPR: JHW 02/11/09

SIMILAR TO: -

83100-0000-16

REV SHEET 2 OF 8

SOLID WIRE CABLE CONNECTION

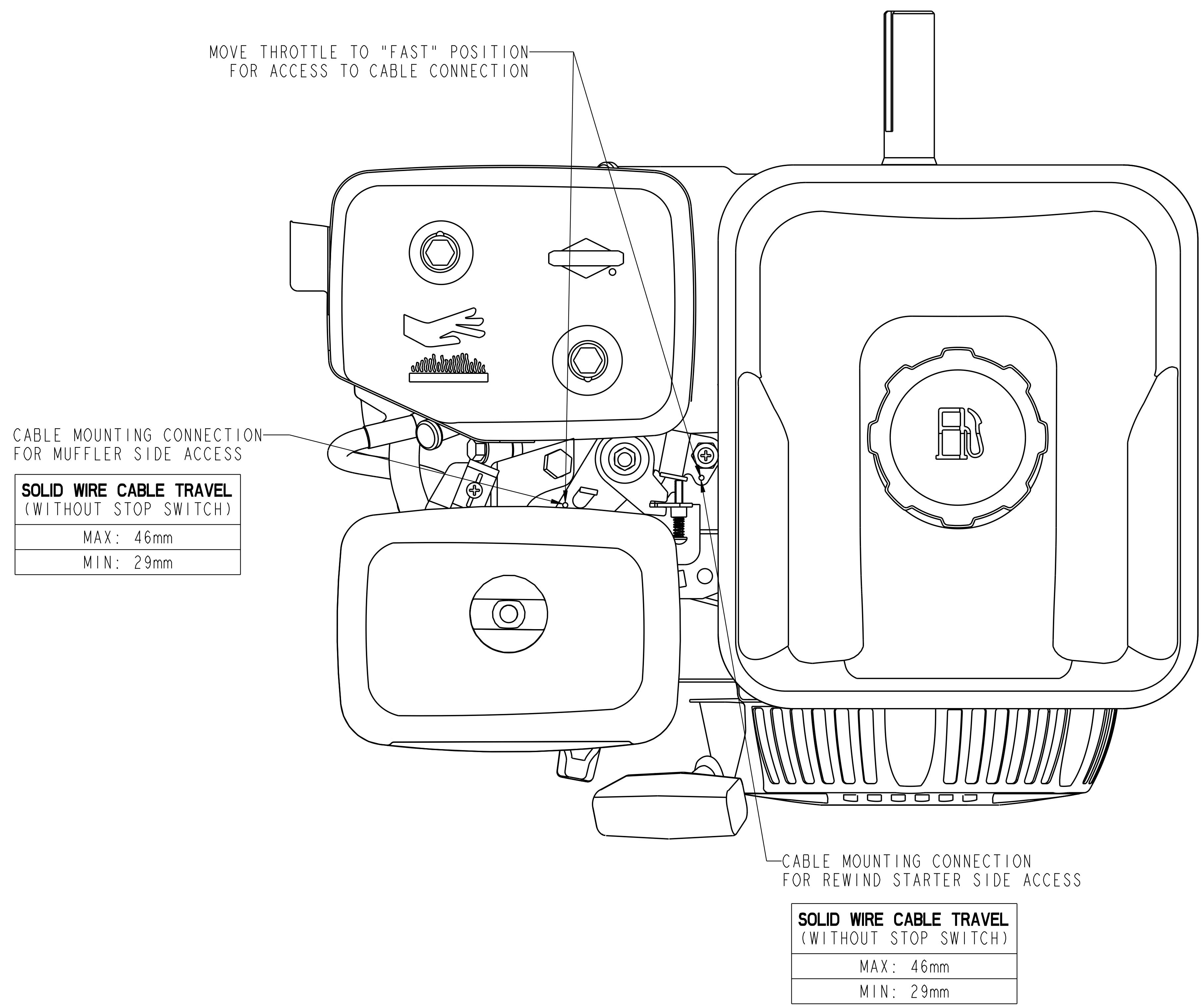

BRAIDED WIRE CABLE CONNECTION

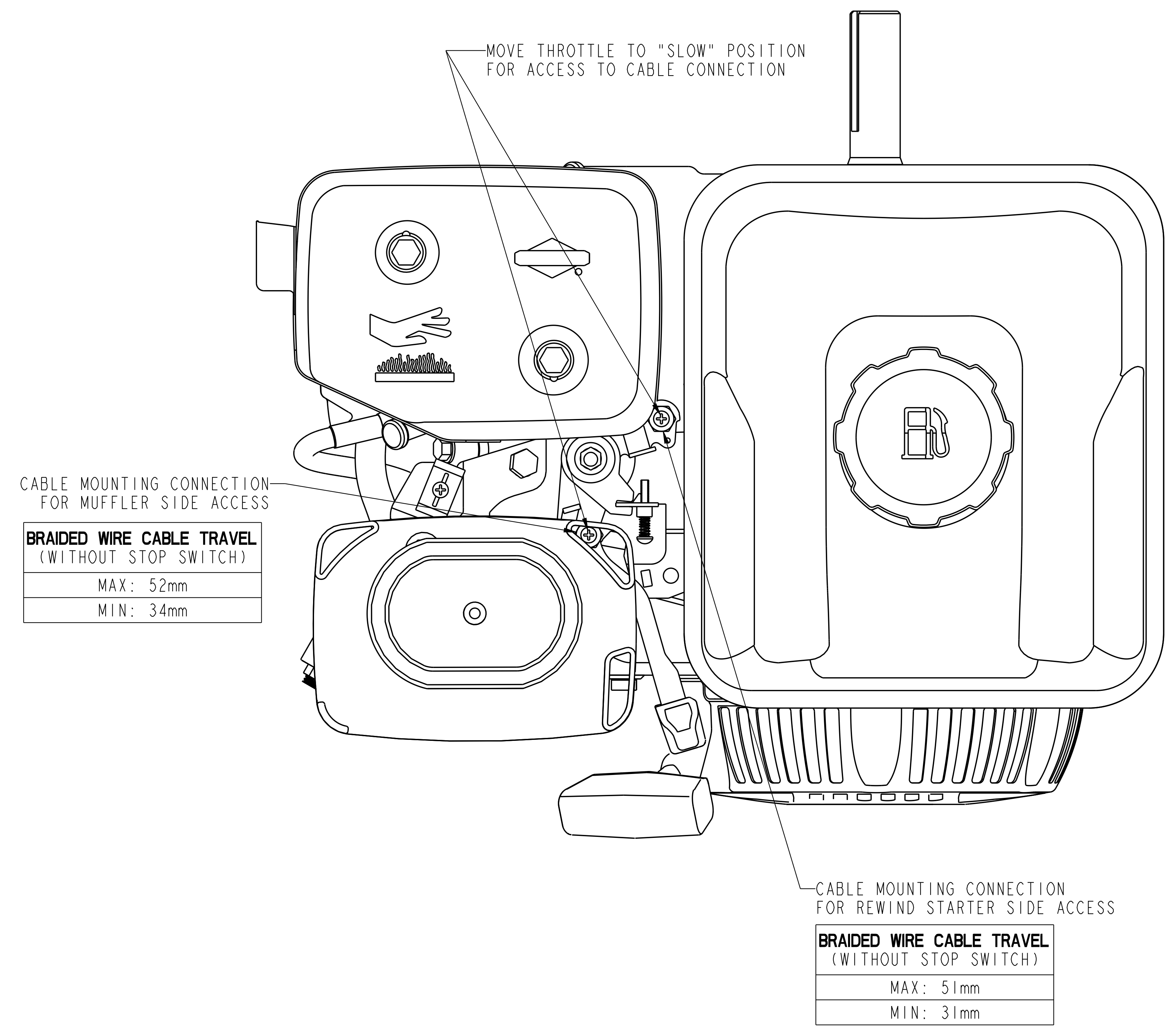

REMOTE CABLE MANUAL FRICTION SPEED CONTROL OPTIONS

"OVAL-STYLE" AIR CLEANER

REV	CHANGES	BY	DOC. NO.	DATE
-	RELEASED FOR PRODUCTION	DTS	ERN10385	02/11/09
A	REDRAWN: ADDED SHEETS SHOWING ENGINE OPTIONS	DTS	ECO17477	06/22/09

REFER TO 3-D DATA FOR ADDITIONAL INFORMATION

THIS DRAWING IS PROPRIETARY PROPERTY OF BRIGGS & STRATTON CORPORATION. IT IS TO BE USED ONLY FOR THE PURPOSES SPECIFIED HEREIN. RETURN PROMPTLY AFTER USE.

DIMENSIONS IN MILLIMETERS

CLASSIFICATION OF CHARACTERISTICS

DOUBLE MAJOR (MM..00) CRITICAL (C..00) MAJOR (M..00)

FIRST ANGLE PROJECTION

SCALE: 1:1

UNCONTROLLED DOCUMENT WHEN PRINTED

TITLE: MODEL 831 ENGINE APPLICATION DRAWING

MATERIAL:

DRAWN: DTS 02/10/09

APPR: JHW 02/11/09

DO NOT SCALE DRAWING

BRIGGS & STRATTON

BRIGGS & STRATTON CORP.

83100-0000-16

REV. SHEET 3 of 8

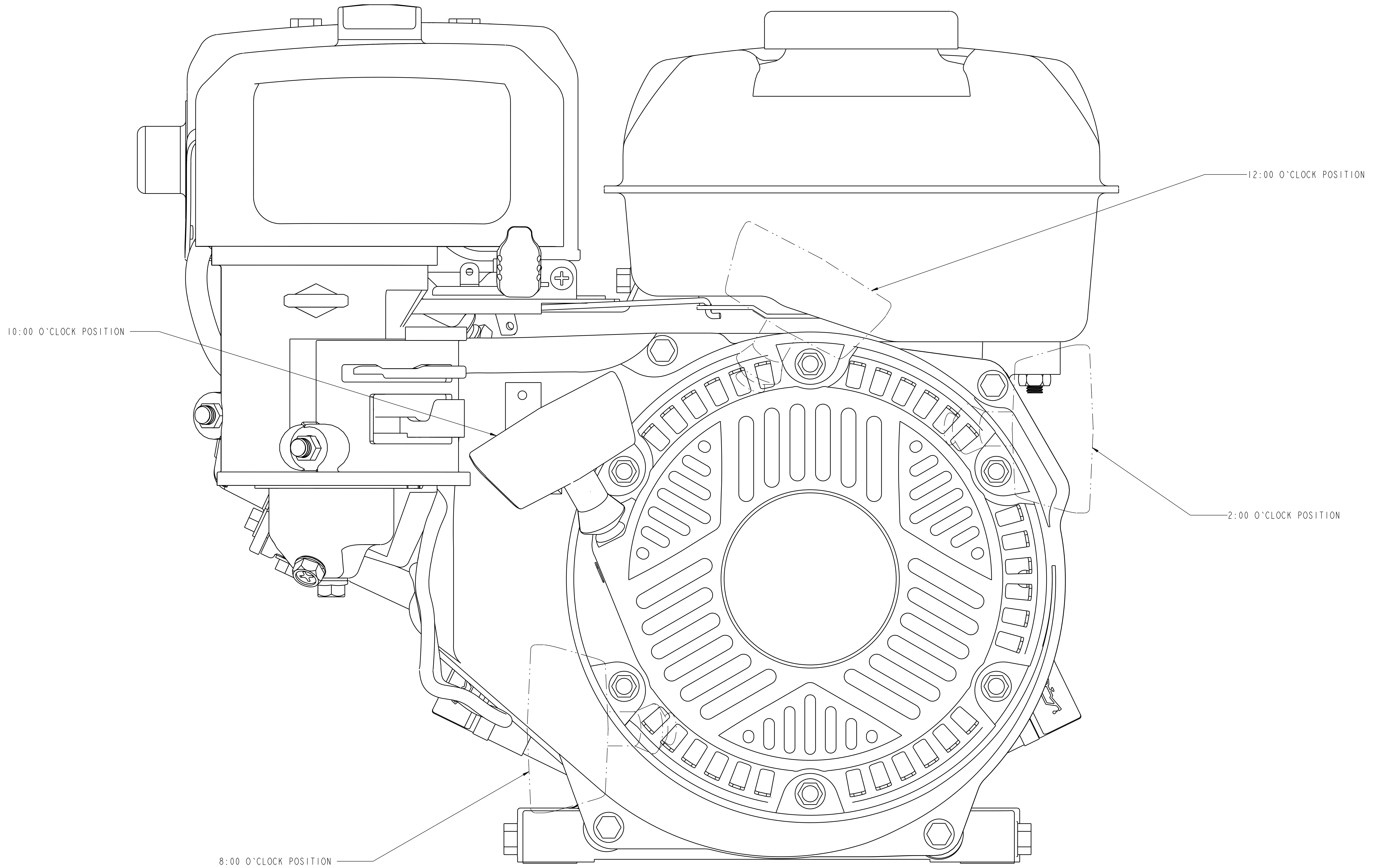

REWIND HANDLE POSITION OPTIONS

"OVAL-STYLE" AIR CLEANER

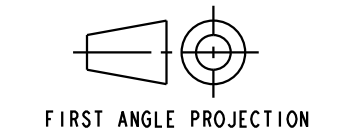

FIRST ANGLE PROJECTION

REFER TO 3-D DATA FOR ADDITIONAL INFORMATION		THIS DRAWING IS PROPRIETARY PROPERTY OF BRIGGS & STRATTON CORPORATION. IT IS TO BE USED ONLY FOR THE PURPOSES SPECIFIED HEREIN. RETURN PROMPTLY AFTER USE.		DIMENSIONS IN MILLIMETERS		TOLERANCING PER ASME Y14.5M-1994		SCALE: 2:1		UNCONTROLLED DOCUMENT WHEN PRINTED	
CLASSIFICATION OF CHARACTERISTICS		DRAWN: DTS 02/10/09		APPR: JHW 02/11/09		MATERIAL:		TITLE: MODEL 831 ENGINE APPLICATION DRAWING		BRIGGS & STRATTON	
DOUBLE MAJOR(MM-.00)		CRITICAL(C-.00)		MAJOR(M-.00)		SIMILAR TO: -		83100-0000-16		REV SHEET 4 of 8	

REV	CHANGES	BY	DOC. NO.	DATE
-	RELEASED FOR PRODUCTION	DTS	ERN10385	02/11/09
A	REDRAWN: ADDED SHEETS SHOWING ENGINE OPTIONS	DTS	ECO17477	06/22/09

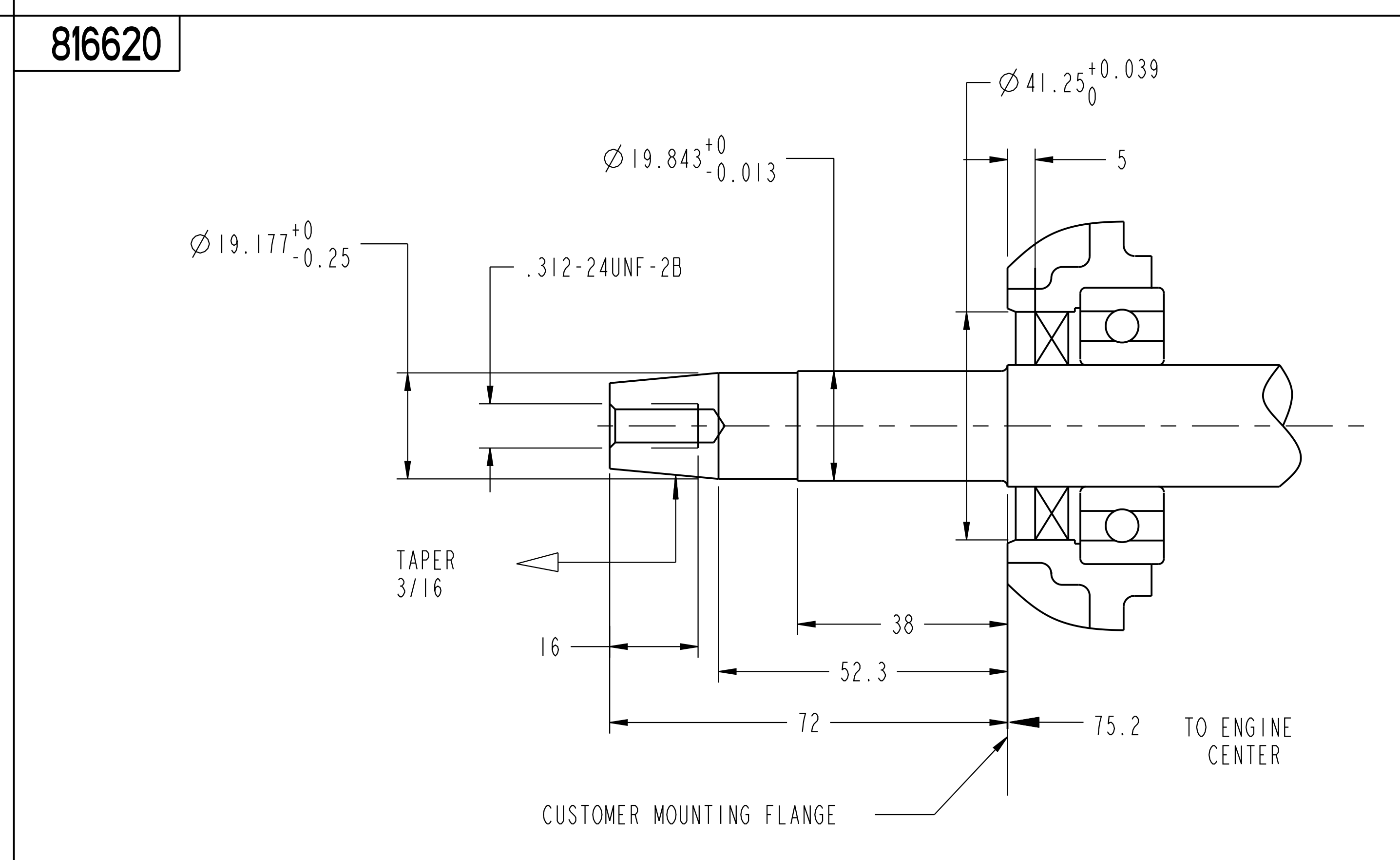
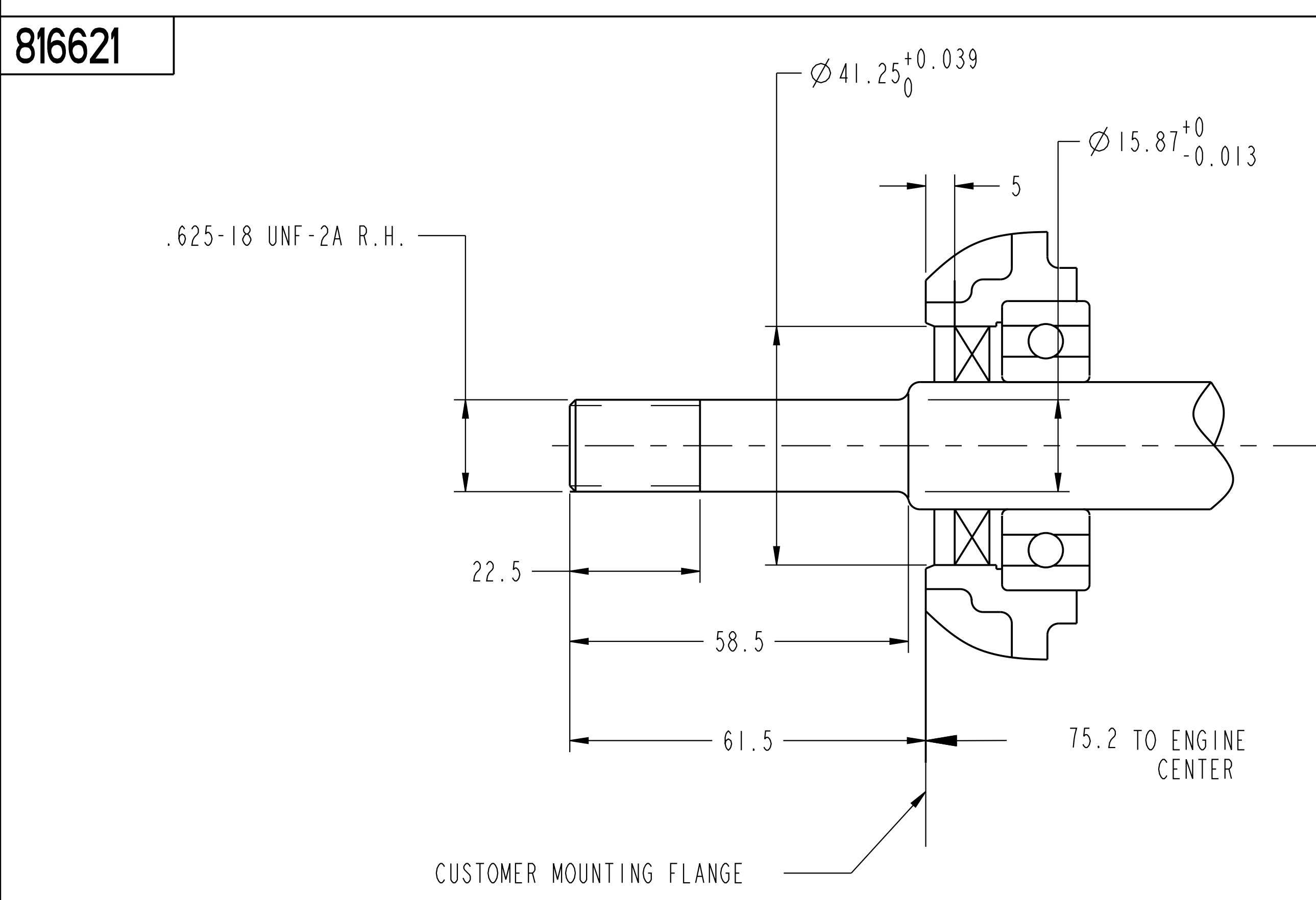
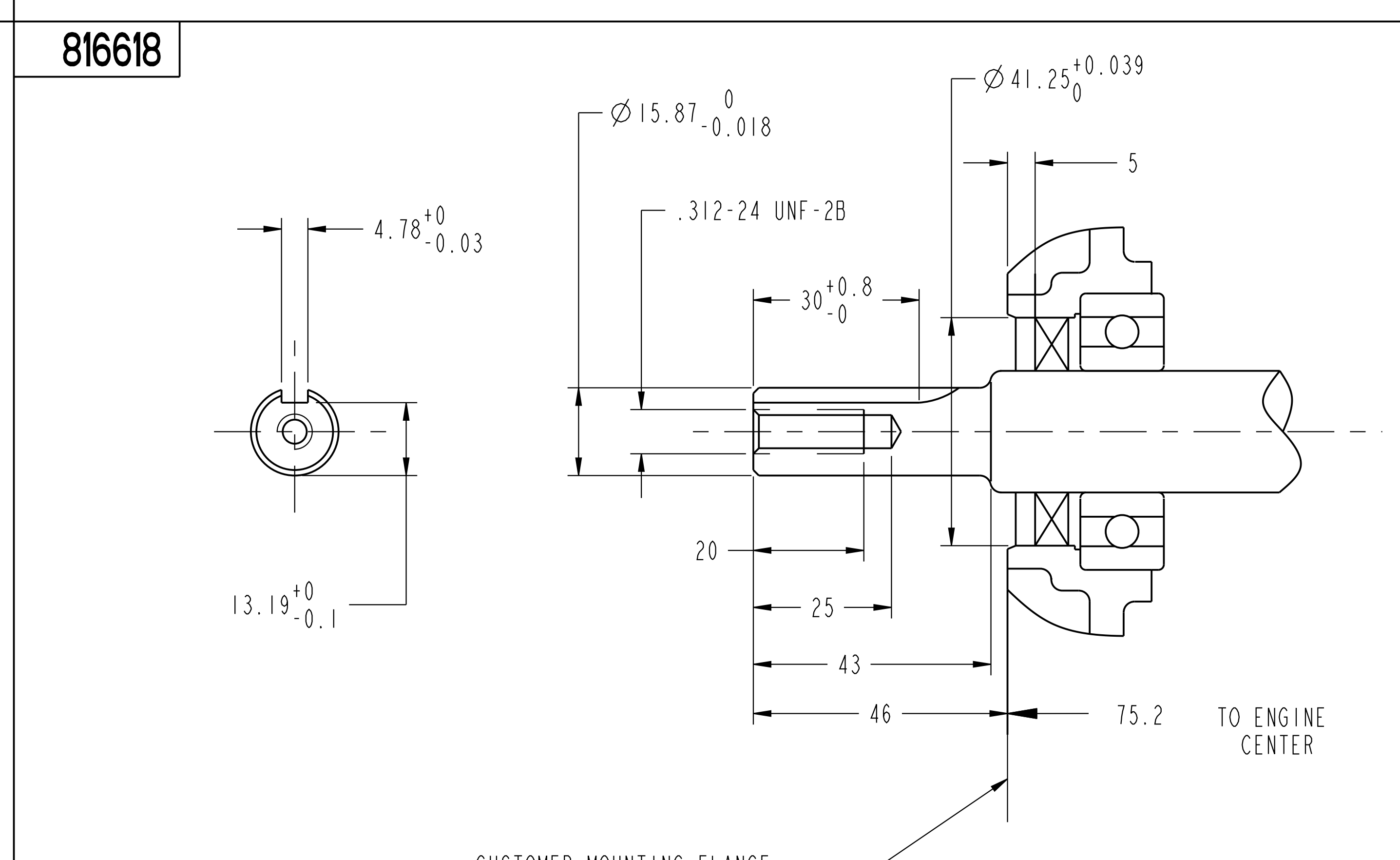
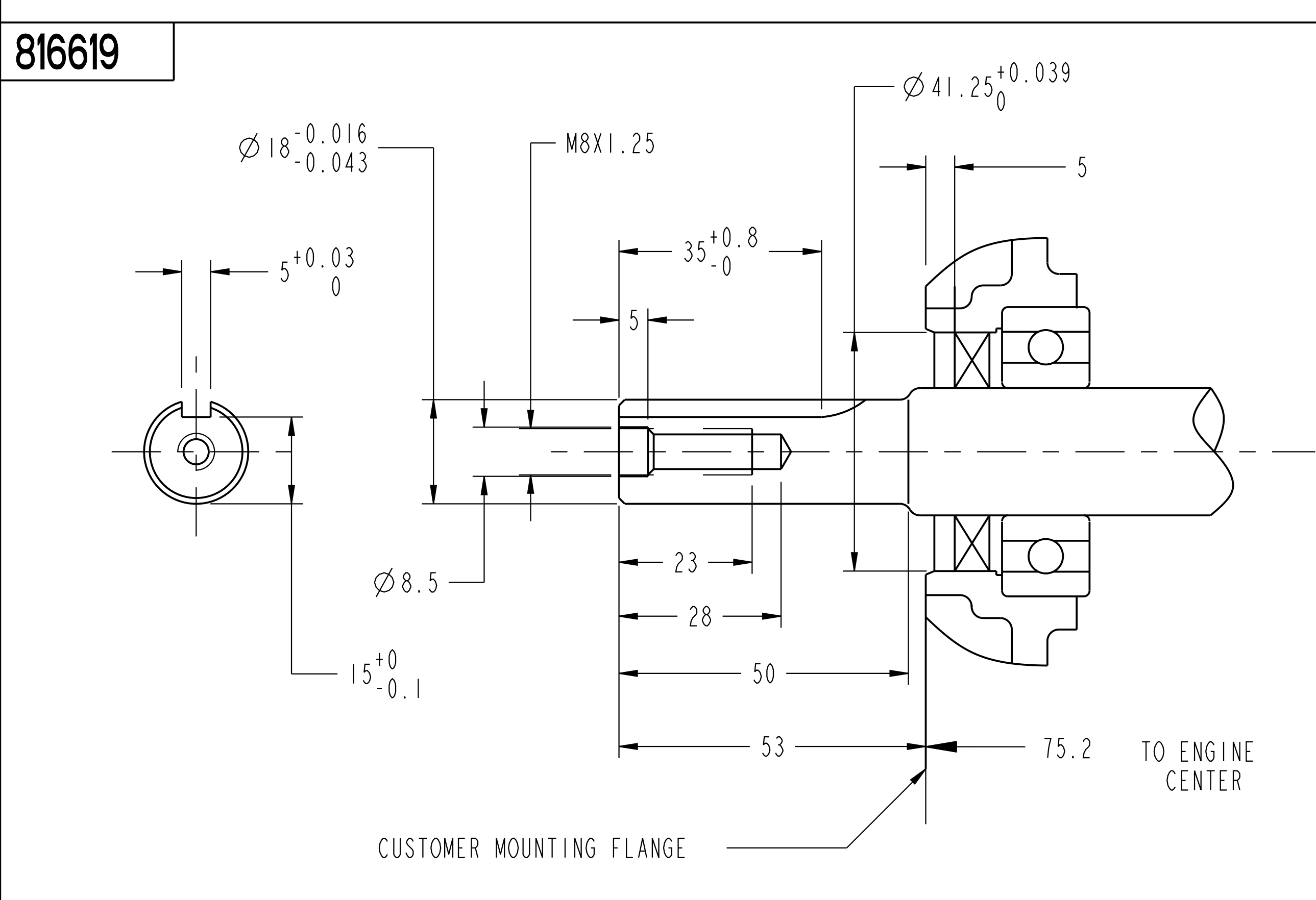
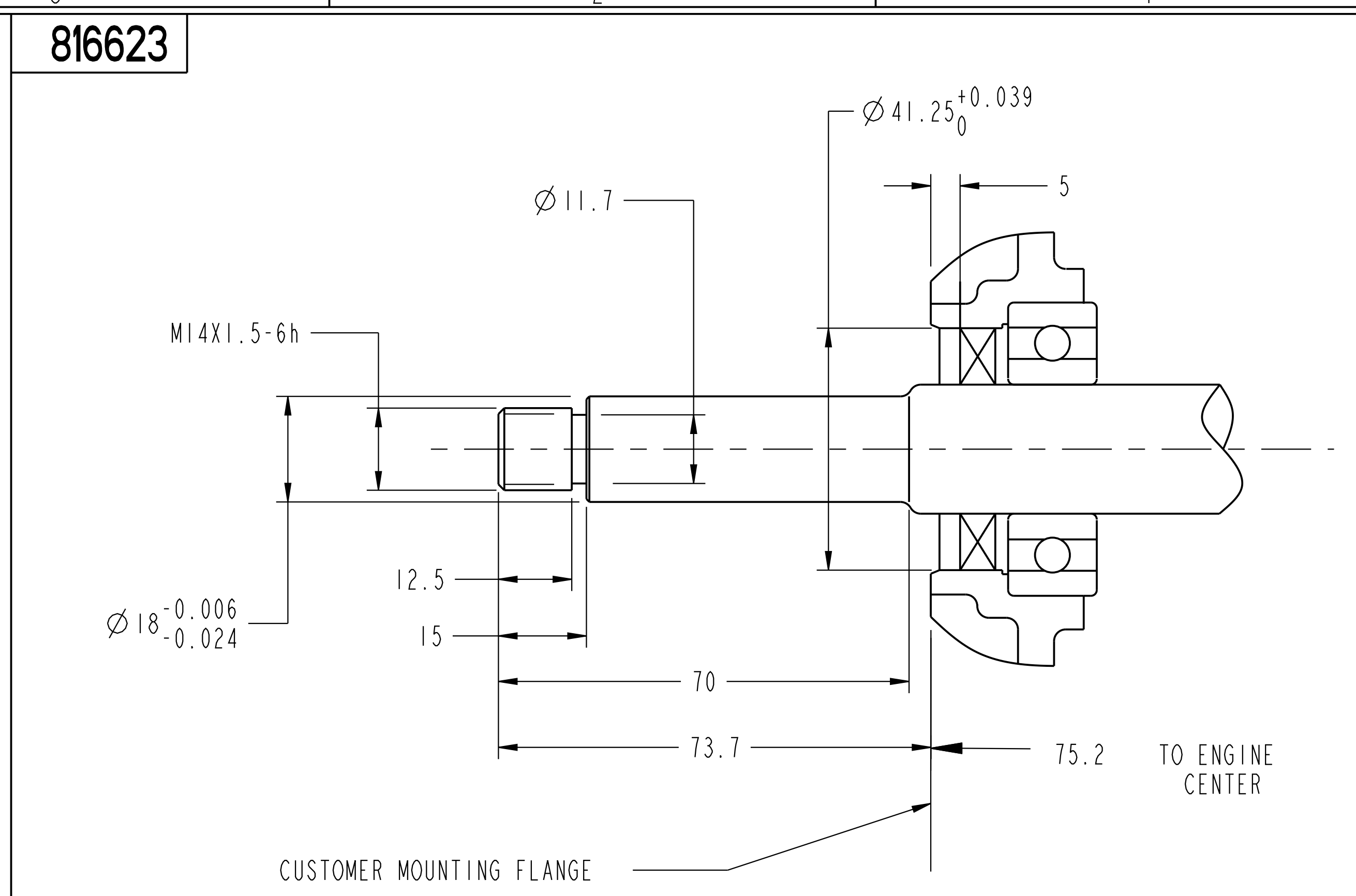
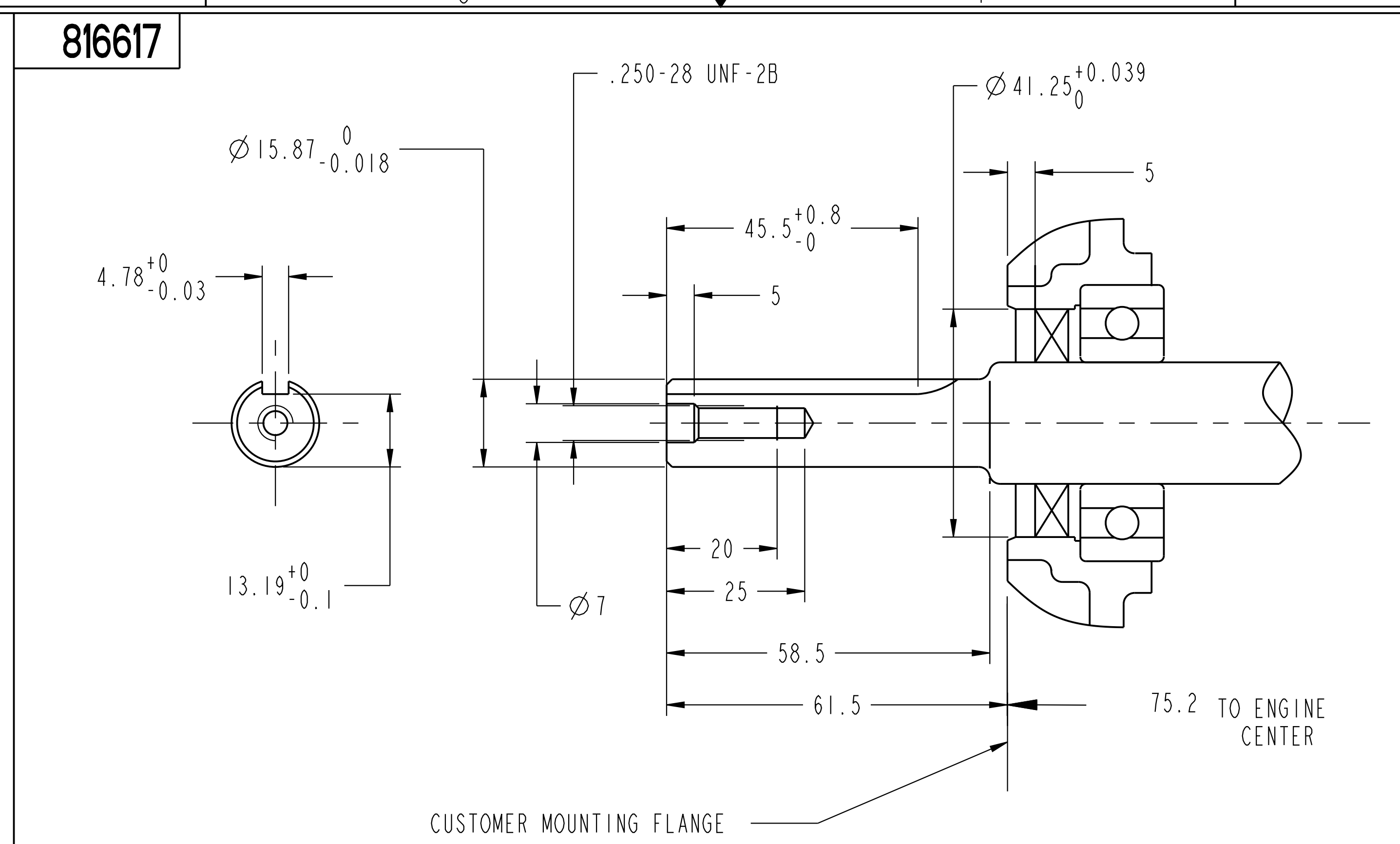
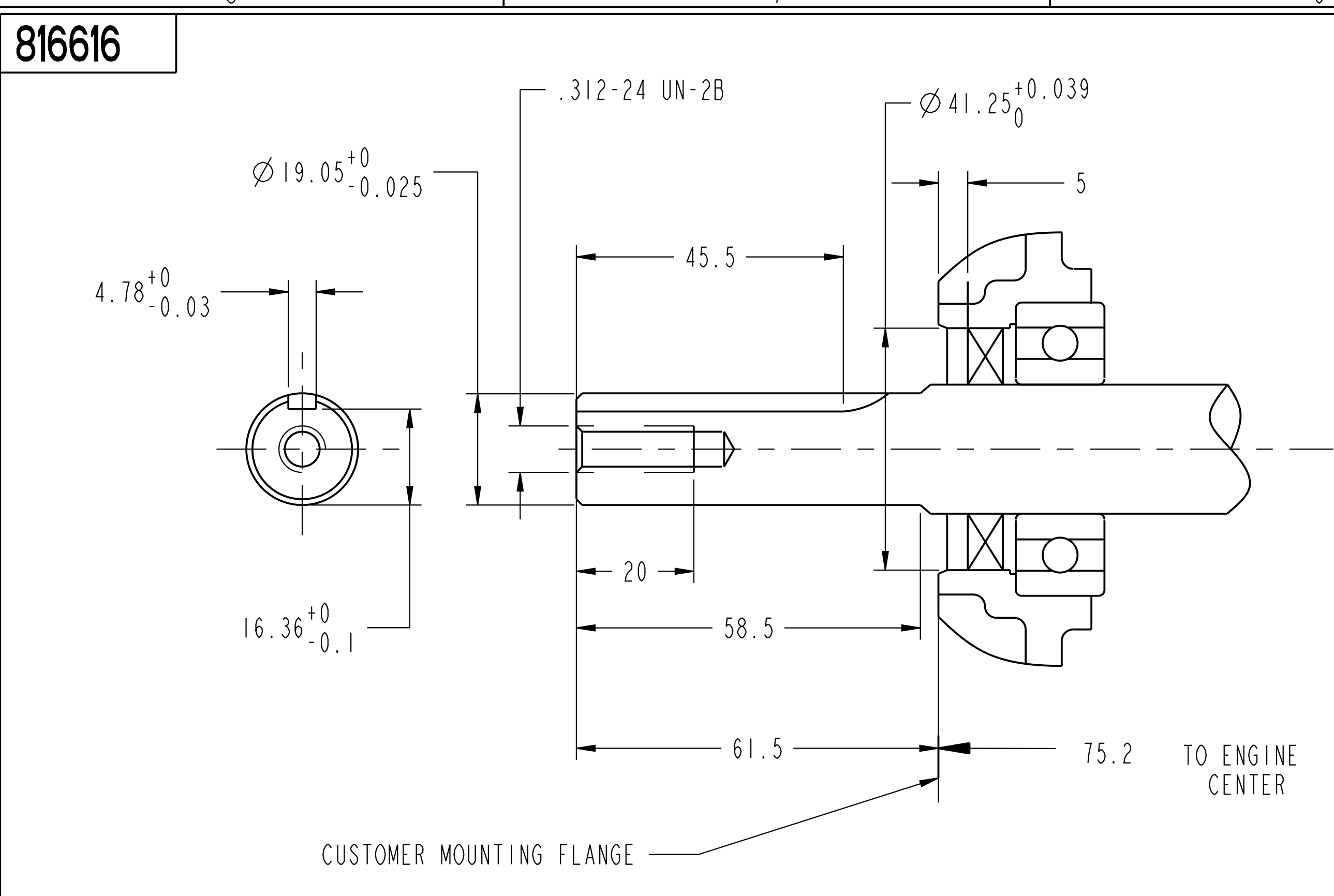

CRANKSHAFT EXTENSION OPTIONS

REV.	CHANGES	BY	DOC. NO.	DATE
-	RELEASED FOR PRODUCTION	DTS	ERN10385	02/11/09
A	REDRAWN: ADDED SHEETS SHOWING ENGINE OPTIONS	DTS	ECO17477	06/22/09

REFER TO 3-D DATA FOR ADDITIONAL INFORMATION

THIS DRAWING IS PROPRIETARY PROPERTY OF BRIGGS & STRATTON CORPORATION. IT IS TO BE USED ONLY FOR THE PURPOSES SPECIFIED HEREIN. RETURN PROMPTLY AFTER USE.

DIMENSIONS IN MILLIMETERS

CLASSIFICATION OF CHARACTERISTICS

DOUBLE MAJOR (MM.00) CRITICAL (C..00) MAJOR (M..00)

FIRST ANGLE PROJECTION

SCALE: 1.5:1

UNCONTROLLED DOCUMENT WHEN PRINTED

TITLE: MODEL 831 ENGINE APPLICATION DRAWING

MATERIAL:

DRAWN: DTS 02/10/09
 APPR: JHW 02/11/09

SIMILAR TO: -

83100-0000-16

REV. SHEET 5 of 8

DO NOT SCALE DRAWING

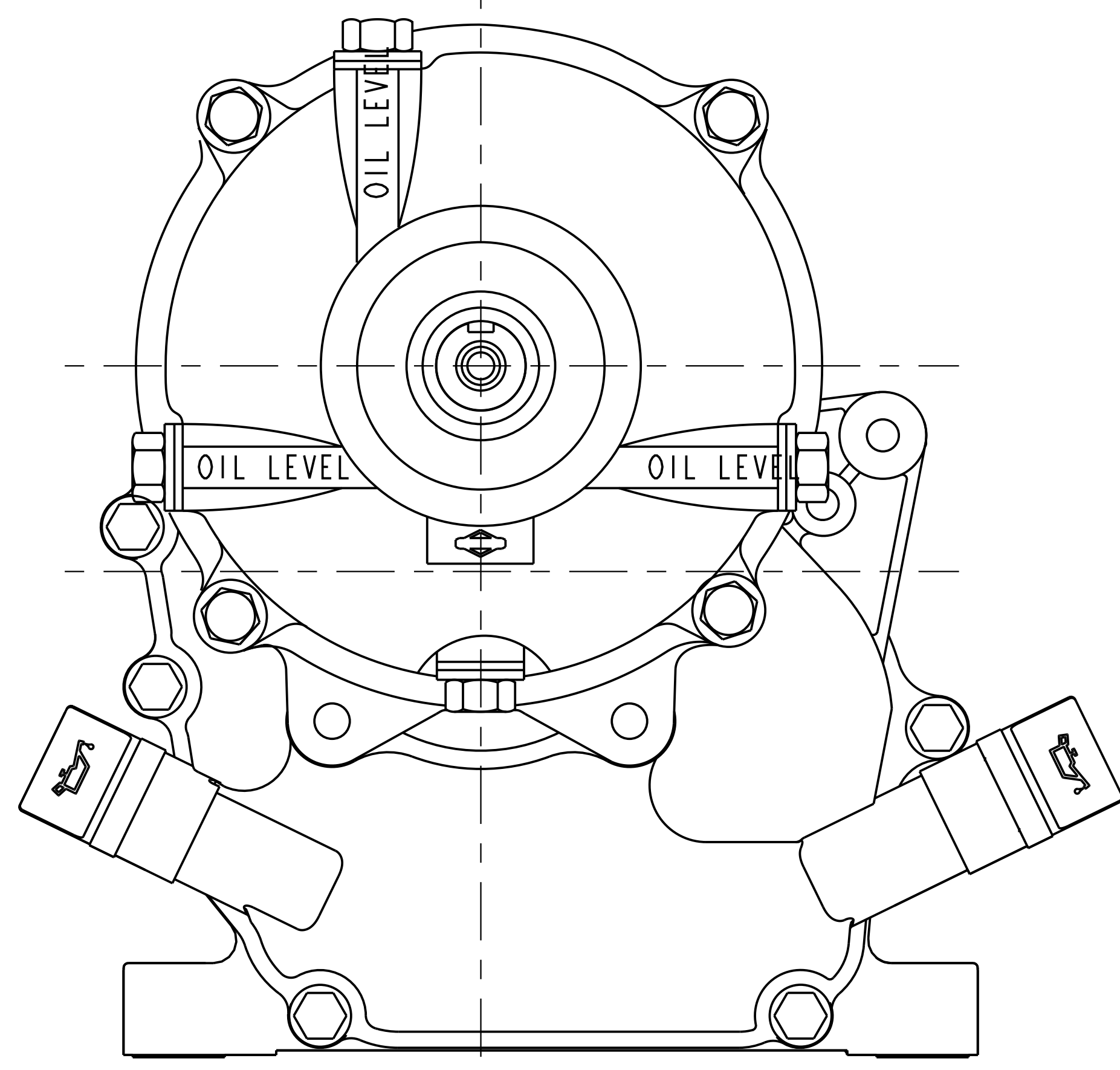

12:00 O'CLOCK POSITION

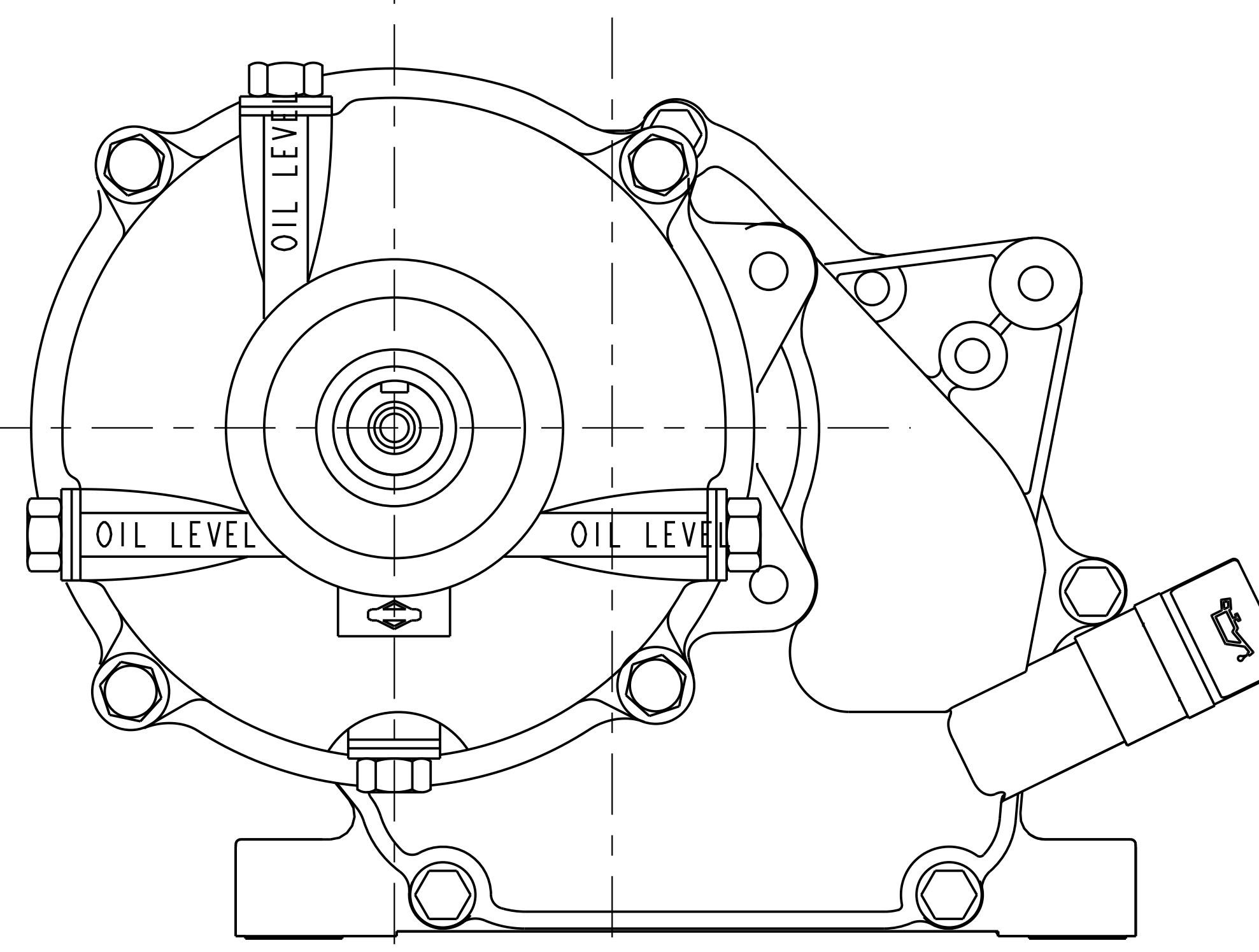

9:00 O'CLOCK POSITION

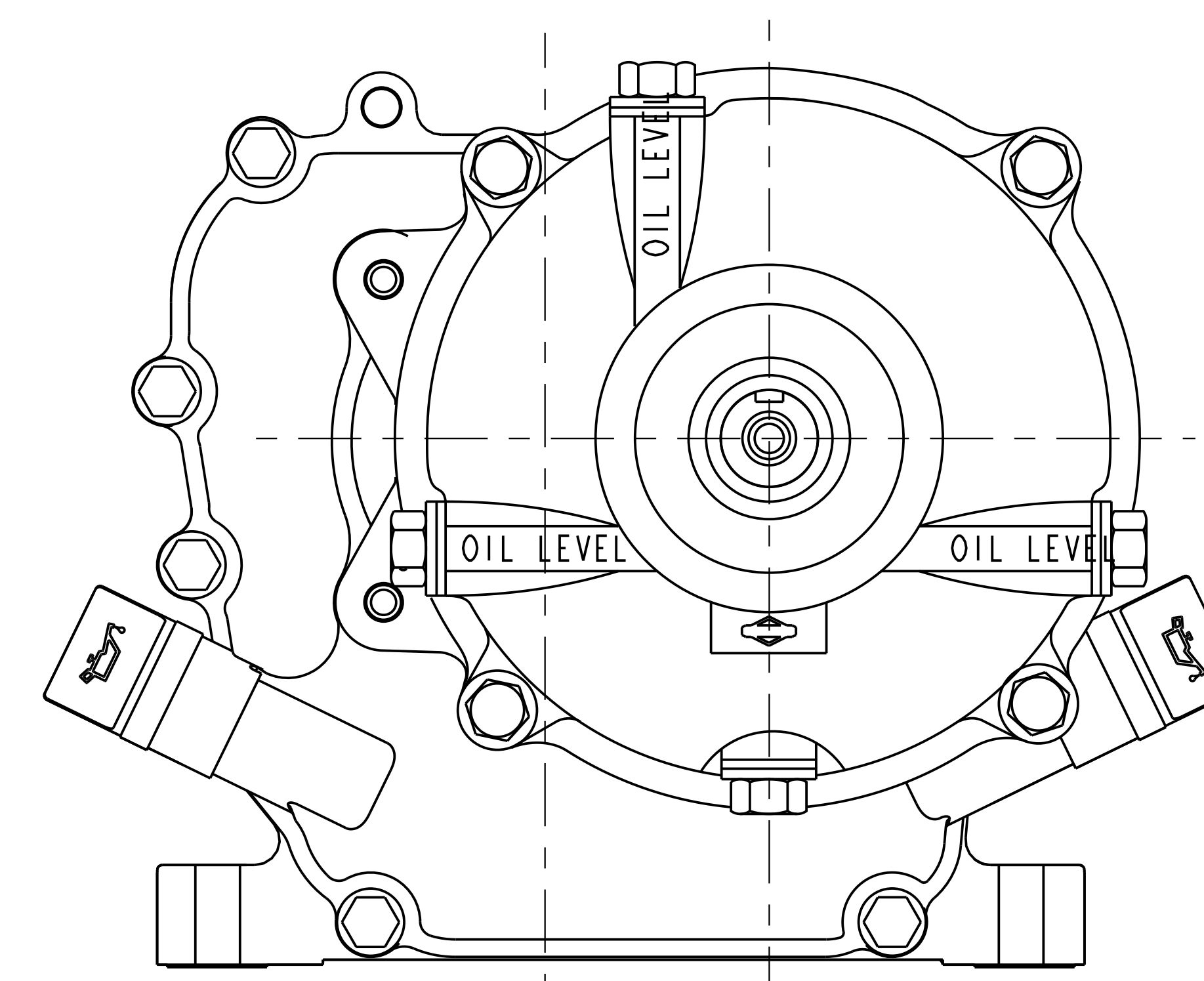

3:00 O'CLOCK POSITION

AVAILABLE GEAR CASE POSITIONS

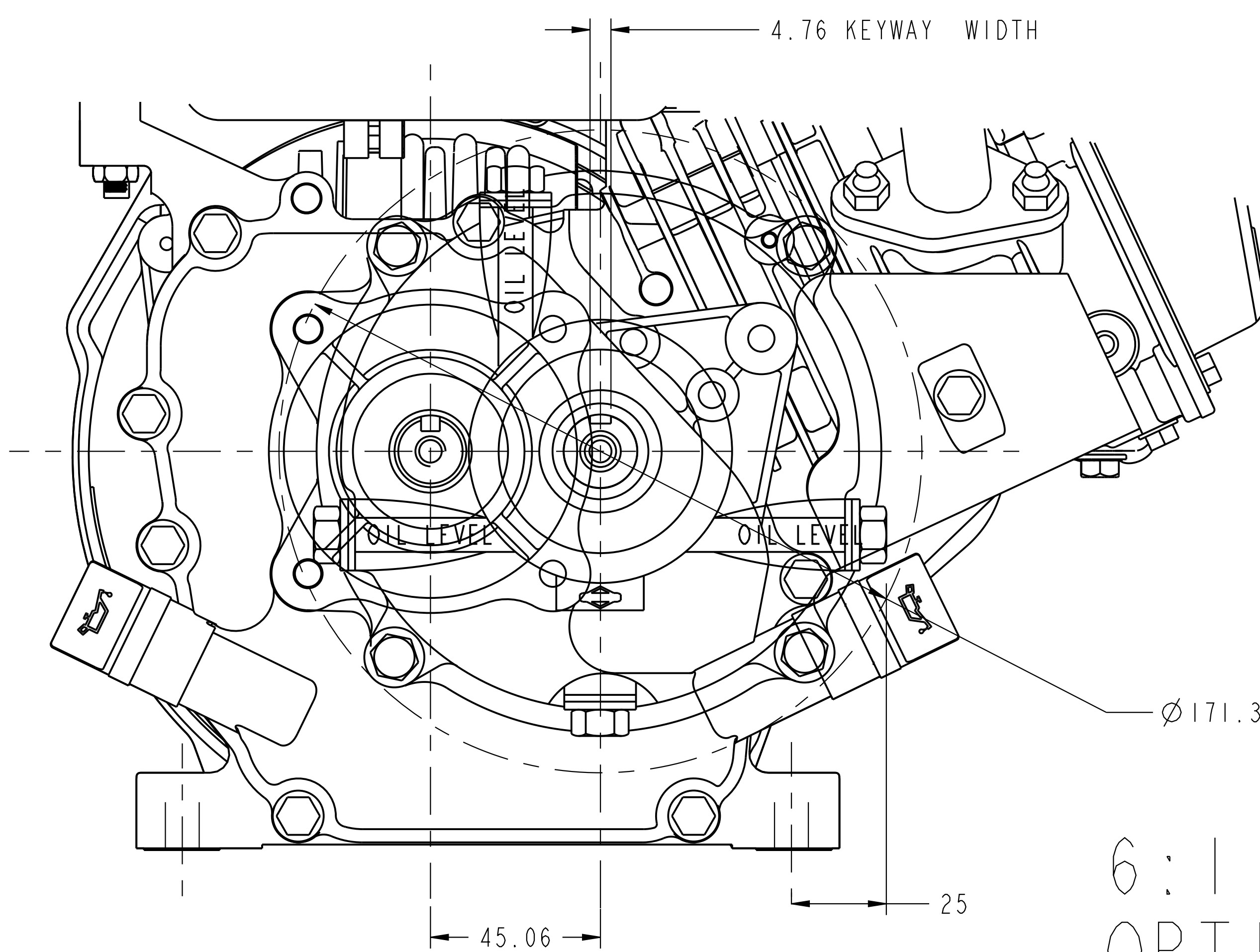
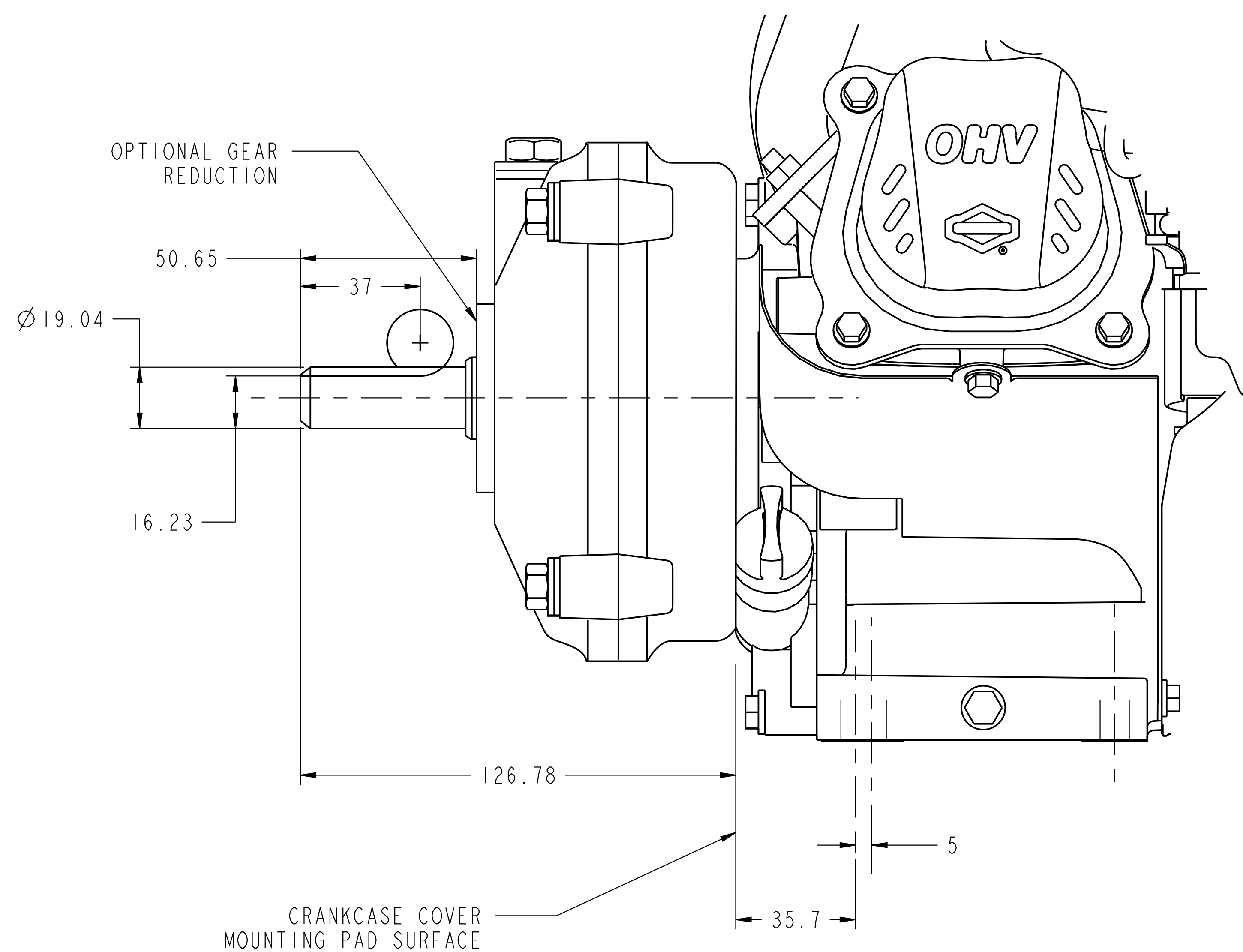

6:1 GEAR REDUCTION OPTION

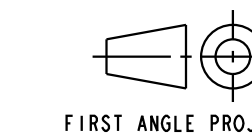
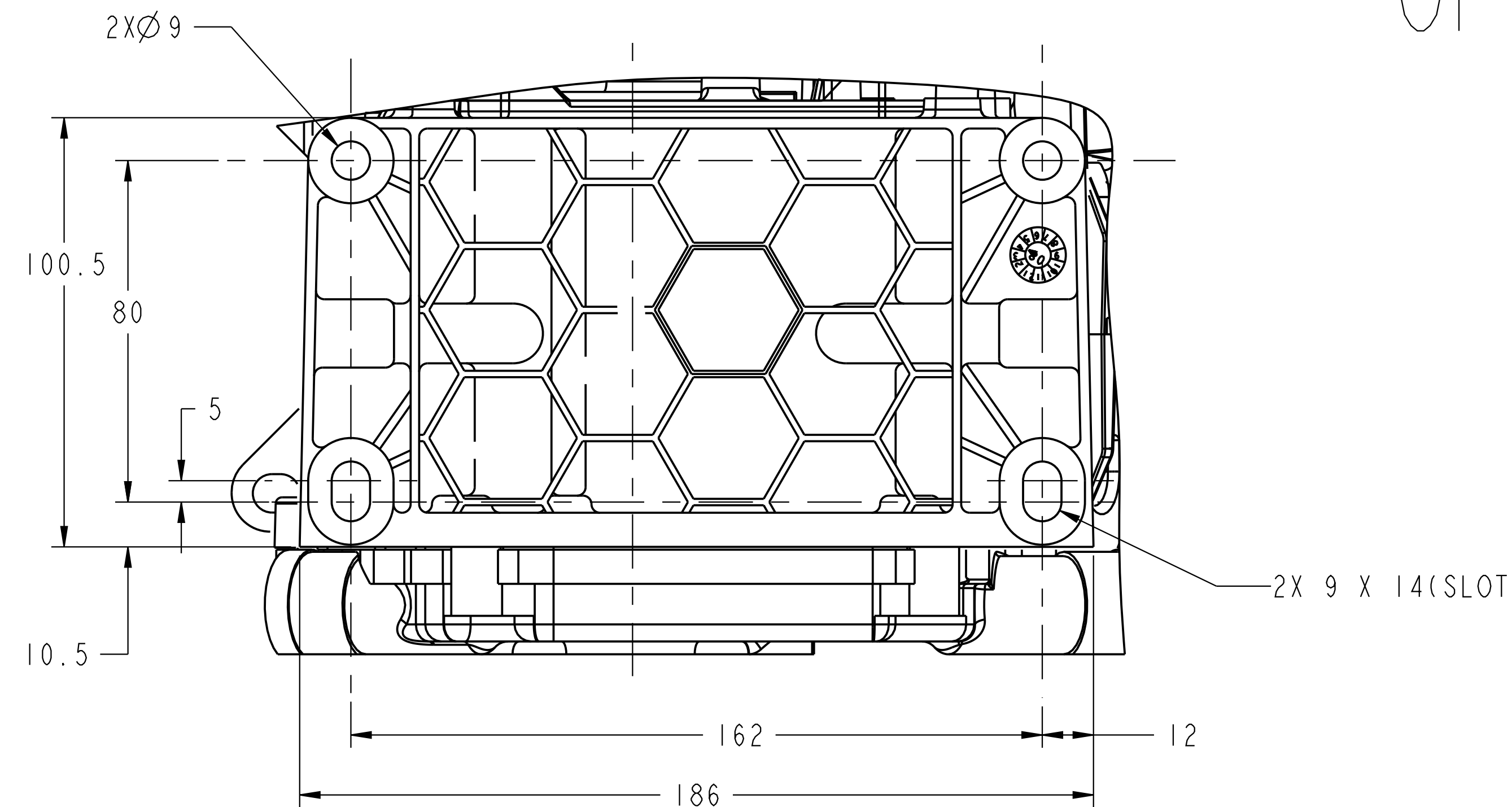

FIRST ANGLE PROJECTION

REFER TO 3-0 DATA FOR ADDITIONAL INFORMATION		DIMENSIONS IN MILLIMETERS		SCALE: 1:1		UNCONTROLLED DOCUMENT WHEN PRINTED	
THIS DRAWING IS PROPRIETARY PROPERTY OF BRIGGS & STRATTON CORPORATION. IT IS TO BE USED ONLY FOR THE PROJECT AND RETURN PROMPTLY AFTER USE.		DIMENSIONING AND SIZE TOLERANCING PER ASME Y14.5M-1994		E		BRIGGS & STRATTON CORP.	
CLASSIFICATION OF CHARACTERISTICS		MATERIAL:		DRAWN: DTS 02/11/09		SIMILAR TO: -	
DOUBLE MAJOR(MM-.00) CRITICAL(C-.00) MAJOR(M-.00)		APPR: JHW 02/11/09		83100-0000-16		REV SHEET 6 of 8	

REV	CHANGES	BY	DOC. NO.	DATE
-	RELEASED FOR PRODUCTION	DTS	ERN10385	02/11/09
A	REDRAWN: ADDED SHEETS SHOWING ENGINE OPTIONS	DTS	ECO17477	06/22/09

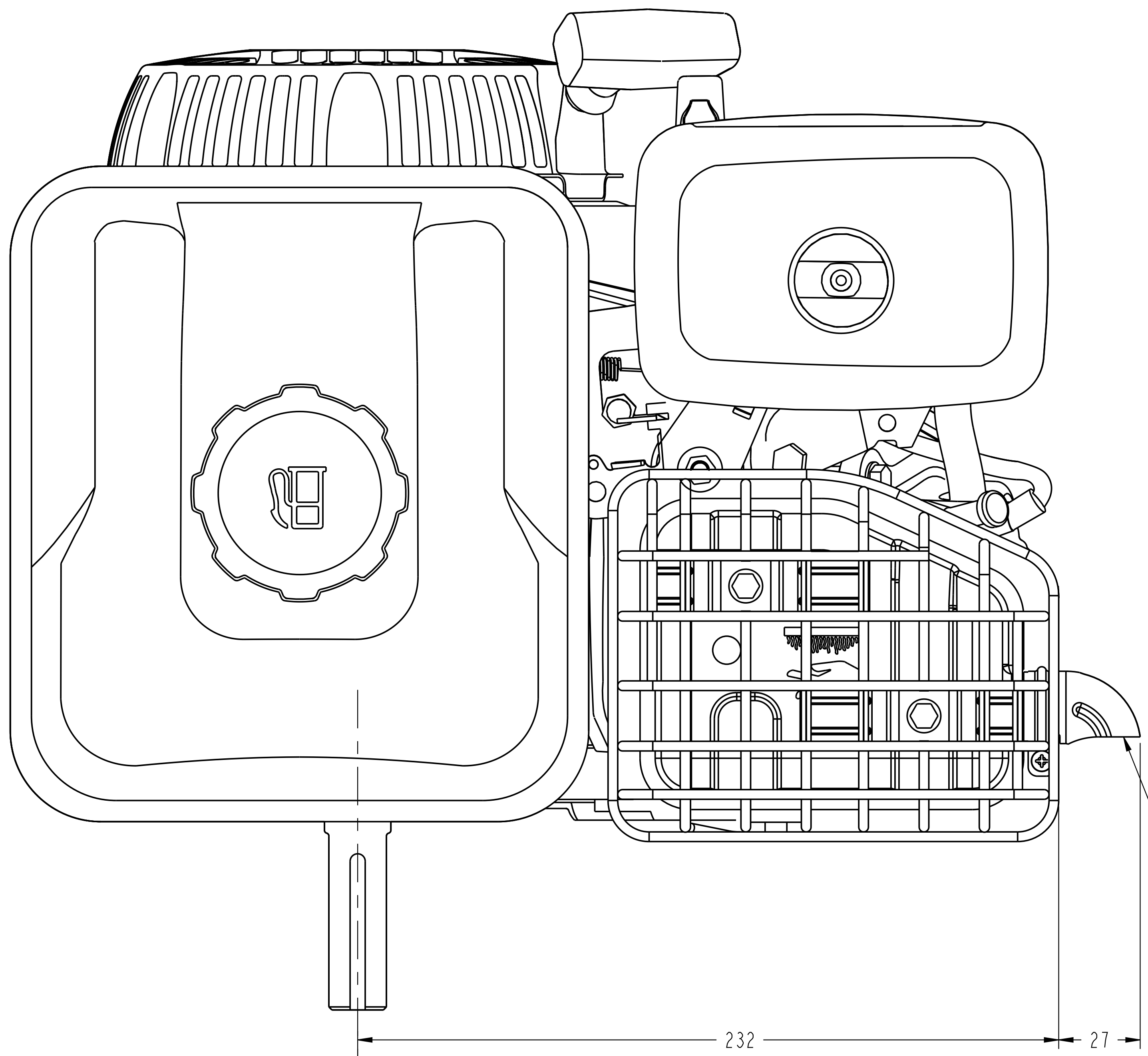
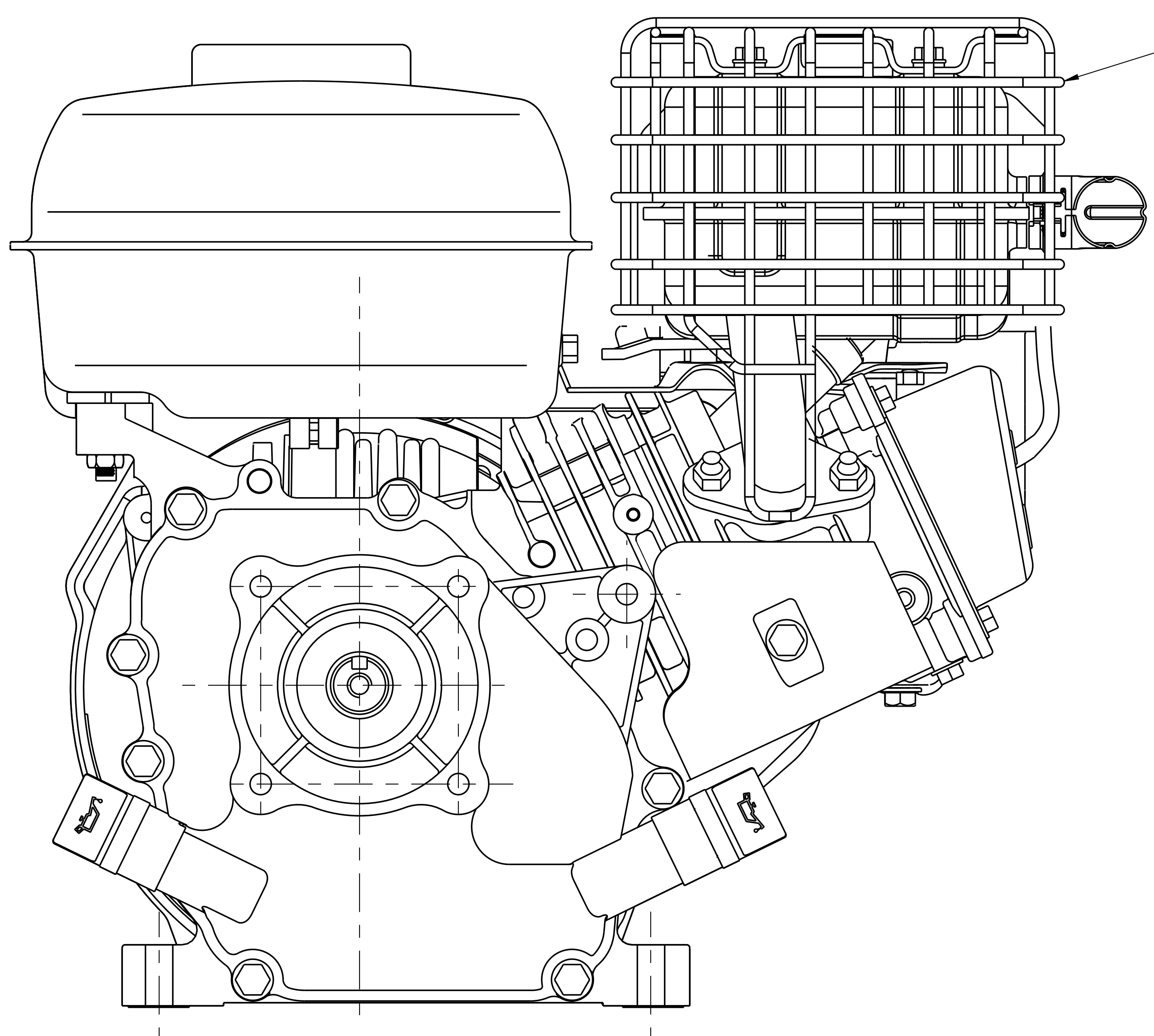
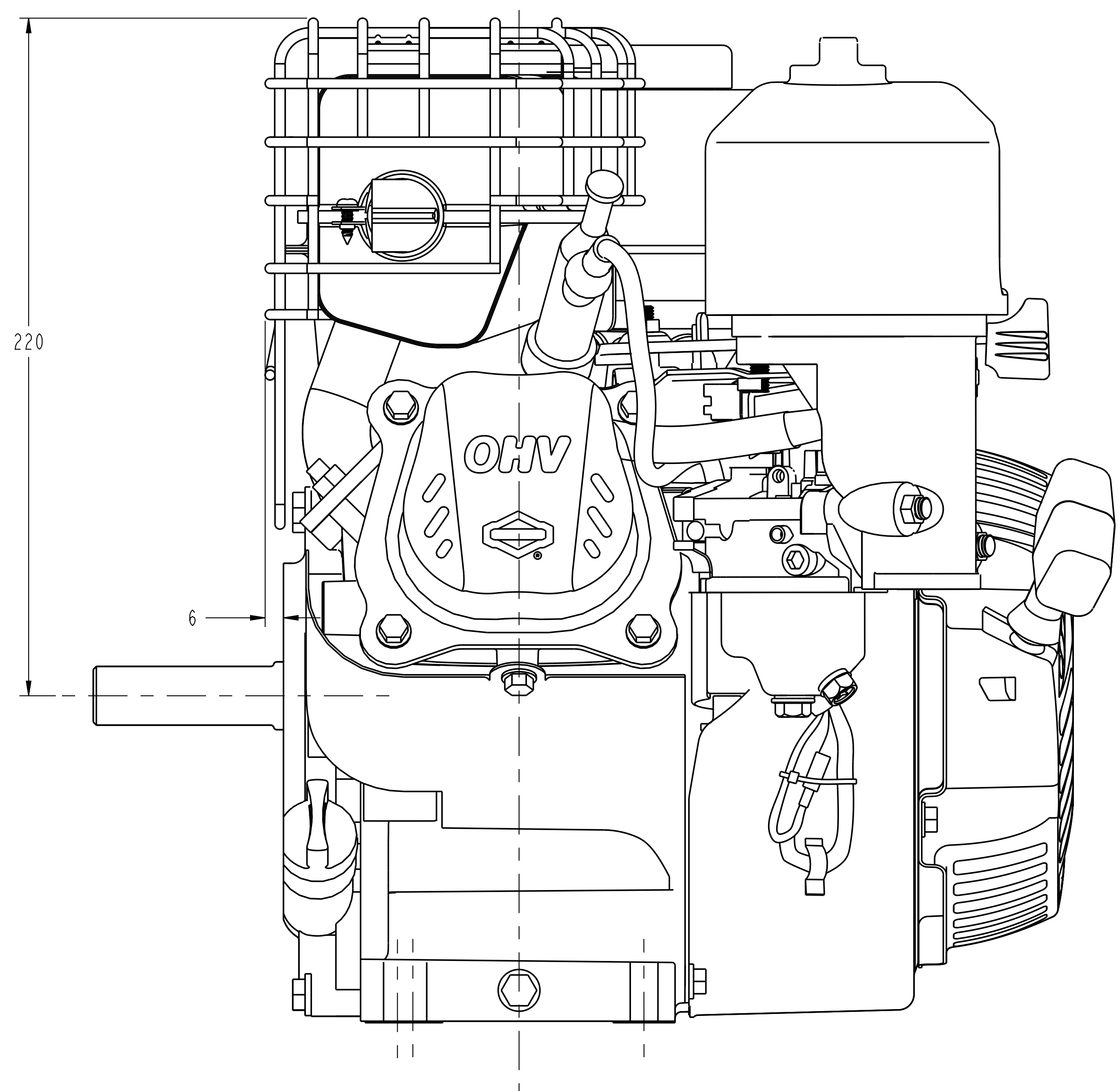

**"OVAL-STYLE" AIR CLEANER
WITH WIRE MUFFER GUARD**

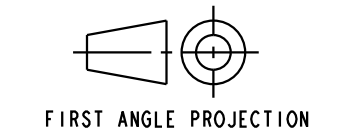

REFER TO 3-D DATA FOR ADDITIONAL INFORMATION		PROPERTY OF BRIGGS & STRATTON CORPORATION. THIS DRAWING IS PROPRIETARY AND IS NOT TO BE REPRODUCED OR TRANSMITTED IN ANY FORM OR BY ANY MEANS, ELECTRONIC OR MECHANICAL, INCLUDING PHOTOCOPYING, RECORDING, OR BY ANY INFORMATION STORAGE AND RETRIEVAL SYSTEM. WITHOUT PERMISSION IN WRITING FROM BRIGGS & STRATTON, RETURN PROMPTLY AFTER USE.		DIMENSIONS AND SIZE TOLERANCING PER ASME Y14.5M-1994		SCALE: 1:1		UNCONTROLLED DOCUMENT WHEN PRINTED	
CLASSIFICATION OF CHARACTERISTICS		MATERIAL:		DRAWN: DTS 02/10/09		SIMILAR TO: -		REV. SHEET	
DOUBLE MAJOR(MM...00) CRITICAL(C...00) MAJOR(M...00)		APPR: JHW 02/11/09		DO NOT SCALE DRAWING		83100-0000-16		A 17 of 18	

REV.	CHANGES:	BY	DOC. NO.	DATE
-	RELEASED FOR PRODUCTION	DTS	ERN10385	02/11/09
A	REDRAWN: ADDED SHEETS SHOWING ENGINE OPTIONS	DTS	ECO17477	06/22/09

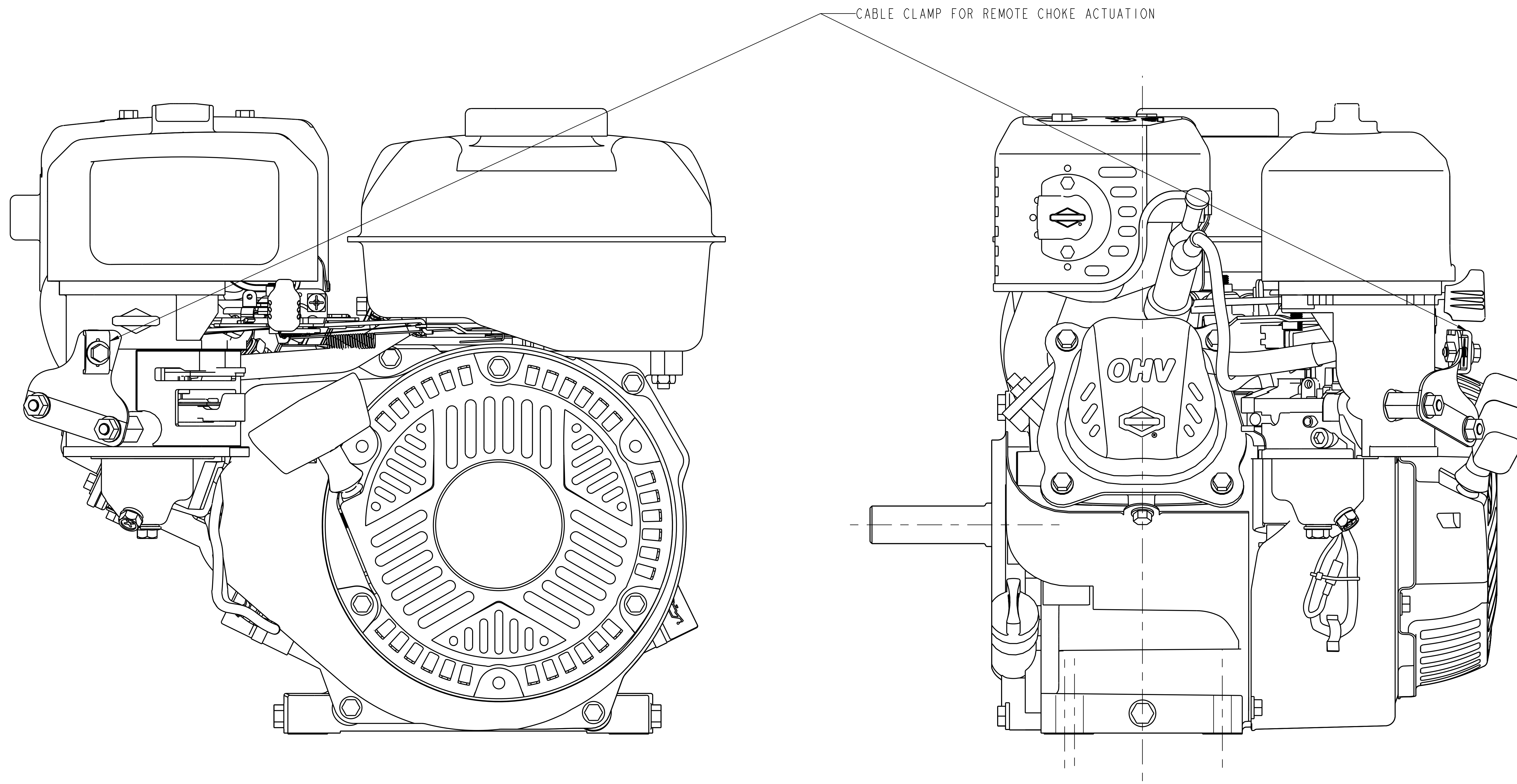

REMOTE CHOKE OPTION

"OVAL-STYLE" AIR CLEANER

REV.	CHANGES:	BY	DOC. NO.	DATE
-	REDUCED FOR PRODUCTION	DTS	ERN10385	02/11/09
A	REDRAWN: ADDED SHEETS SHOWING ENGINE OPTIONS	DTS	ECO17477	06/22/09

<small>REFER TO 3-D DATA FOR ADDITIONAL INFORMATION</small> <small>THIS DRAWING IS PROPRIETARY PROPERTY OF BRIGGS & STRATTON CORPORATION. IT IS TO BE USED ONLY FOR THE PURPOSES SPECIFIED HEREIN. RETURN PROMPTLY AFTER USE.</small>	<small>DIMENSIONING AND TOLERANCING PER ASME Y14.5M-1994</small> E		<small>BRIGGS & STRATTON CORP.</small>
<small>SCALE: 1:1</small>	<small>UNCONTROLLED DOCUMENT WHEN PRINTED</small>	<small>TITLE: MODEL 831 ENGINE APPLICATION DRAWING</small>	
<small>CLASSIFICATION OF CHARACTERISTICS</small>	<small>MATERIAL:</small>	<small>DRAWN: DTS 02/10/09</small>	
<small>DOUBLE MAJOR(MM-.001)</small> <small>CRITICAL(C-.001)</small> <small>MAJOR(M-.001)</small>	<small>APPR: JHW 02/11/09</small>	<small>SIMILAR TO: -</small>	<small>REV. SHEET 8 of 8</small>
	<small>DO NOT SCALE DRAWING</small>	<small>83100-0000-16</small>	